

High-Speed-Printer

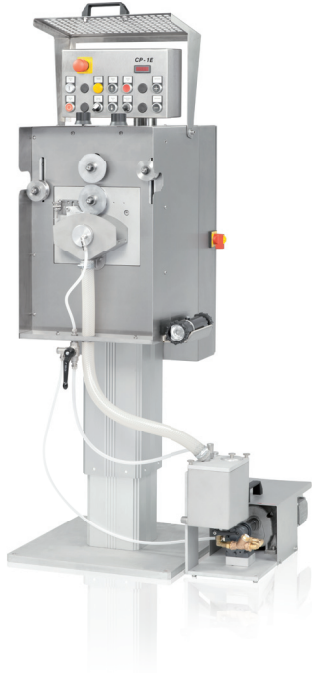

Type of machine	CP1E
Type of printing	direct printing
Drive	electronically controlled
Automatic synchronization with line	yes
Number of printing stations	1
Printing direction	l. → r. / r. → l.
Maximum printing diameter	Ø 0,8 mm - 25 mm (031" - 1")
Lift column electronically adjustable	yes
Print height adjustment	900 mm - 1200 mm (35" - 47")
Maximum printing speed	1500 m/min (4800 fpm)
Printing wheel diameter	Ø 86 mm (3.386")
Mounting hole diameter	12,7 mm (.500")
Ink reservoir	0,5 - 2 L (.13 - .53 GAL)
Suitable for flat printing wheels	yes
Suitable for concave printing wheels	yes
Suitable for embossing/indenting wheels	yes
Printing simulator	yes
Inline-stroboscope lamp(synchronized)	optional
Viscosity control system	optional
Viscosity unit for double ink pump system	optional
Second ink pump unit for quick ink change	optional
Rail mounted	optional
Power Supply	400 V, 50 Hz, 3 Ph
Built-in transformer	optional
Weight	approx. 130 kg (290 LBS)

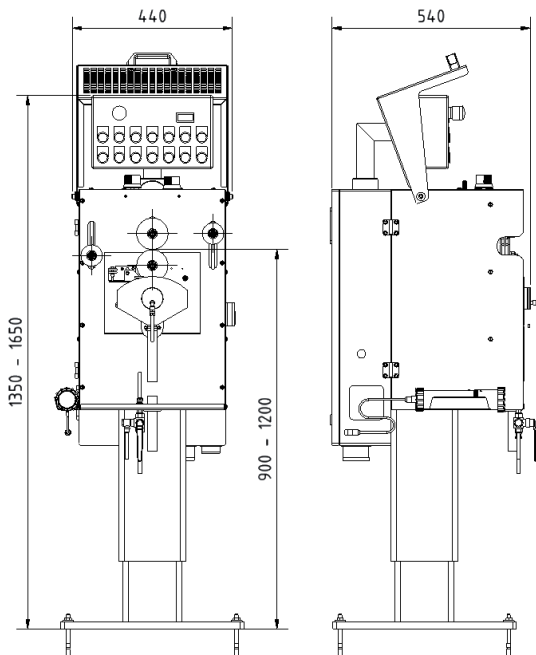

- automatic cable printing machine with electronically controlled print wheel drive
- drive system allows printing speeds up to 1500 m/min. (4800 fpm)
- high speed wiper system
- synchronized inline-stroboscope provides an easy method for examining the printing process

RSD TECHNIK GmbH

Walter-Wetzel-Straße 2 • 79588 Efringen-Kirchen - Germany • Phone +49 7628 802 0
 Fax +49 7628 802 80 Mail: sales@rsdtechnik.de • Web: www.rsdtechnik.com

